

CHALLENGER[®]



1970-74 Front Frame Rails

Order (905) 850-3433 • Fax (905) 850-1722

Goldenleaf Automotive • 170 Zenway Blvd., Unit # 2, Woodbridge, Ontario, Canada, L4H 2Y7

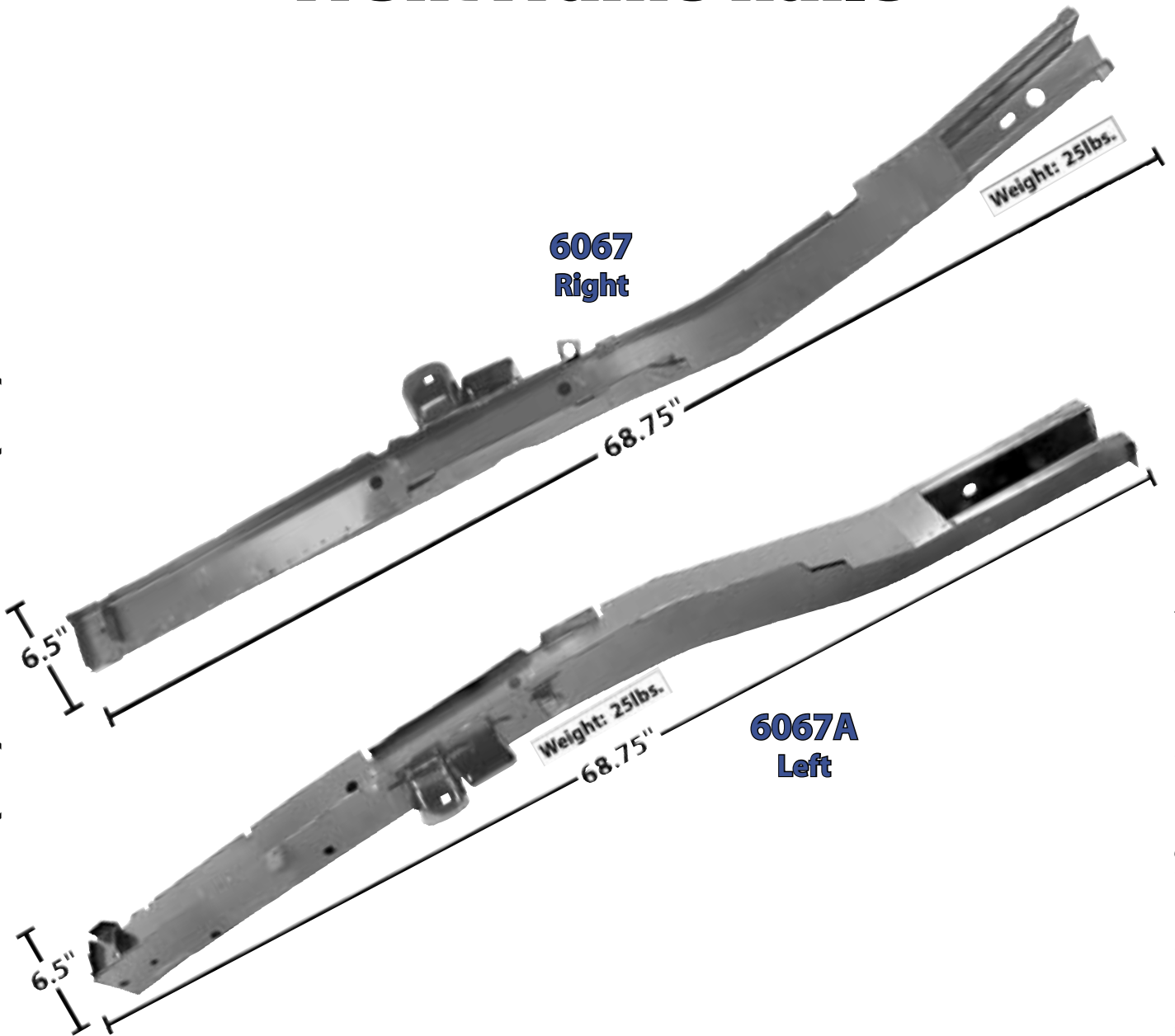

In Stock For June 2009

6067	1970-74	RH Front Frame Rail
6067A	1970-74	LH Front Frame Rail

MSRP \$425 .00 each

Visit us at www.goldenleafautomotive.com

CHALLENGER®

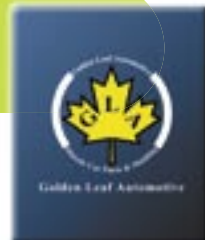

1970-74 Window Regulator with Track



**6054
Right**

Order (905) 850-3433 • Fax (905) 850-1722

In Stock For June 2009

6054	1970-74	RH Window Regulator/Track
6054A	1970-74	LH Window Regulator/Track

MSRP \$250.00 each

Visit us at www.goldenleafautomotive.com

CHALLENGER[®]



1970-74 Tail Lamp Panel Brace



Order (905) 850-3433 • Fax (905) 850-1722

Goldenleaf Automotive • 170 Zenway Blvd., Unit # 2, Woodbridge, Ontario, Canada, L4H 2Y7

In Stock For June 2009

6083A

1970-74

Tail Lamp Panel Brace

MSRP \$60.00 each

Visit us at www.goldenleafautomotive.com

CHALLENGER®



Battery Hold-Down



Order (905) 850-3433 • Fax (905) 850-1722

In Stock For June 2009

6031	1970-71	"A" Body
	1970-71, 1973	"B" Body
	1970-71	"E" Body

MSRP \$12.00 each

Visit us at www.goldenleafautomotive.com